



altair

The Altair™ Microcomputer System—Its multi-purpose capabilities give you the advantage. The versatility inherent in all Altair microcomputer products permits highly individualized, economical system configuration (see Business System below).

With the Altair line, MITS has established uncompromising standards for design efficiency, operational reliability and hardware/software support. From the following pages, choose the system components that best suit your computing needs.



Table of Contents

I. Mainframes	P. 3-8
II. Peripherals	P. 9-15
III. Software	P. 16-20
IV. Plug in Boards	P. 21-28
V. Altair Computer Centers	P. 29



8800b Mainframe

Meticulous engineering and careful planning have resulted in the Altair 8800b, the pacesetter in microcomputer development.

With the vast amount of memory, interface, and process control boards available for the 8800b, expansion capabilities remain unsurpassed.

System flexibility is further enhanced by the potential for many interface possibilities including floppy disk systems, CRT's, line printers, teletypes, paper tape readers, video displays and custom applications control.

The Altair 8800b computer is a general purpose byte-oriented machine with 78 basic machine language instructions. It supports up to 64K of directly addressable memory and can address 256 separate input and output devices.

A heavy duty power supply permits full load (up to 18 plug-in units) operation. The three power lines include an unregulated 8 volt, 18 ampere supply and pre-regulated positive and negative 18 volt, 2 ampere supplies. A multiple tapped primary transformer provides for 110/220 volt and 50/60 Hz operations.

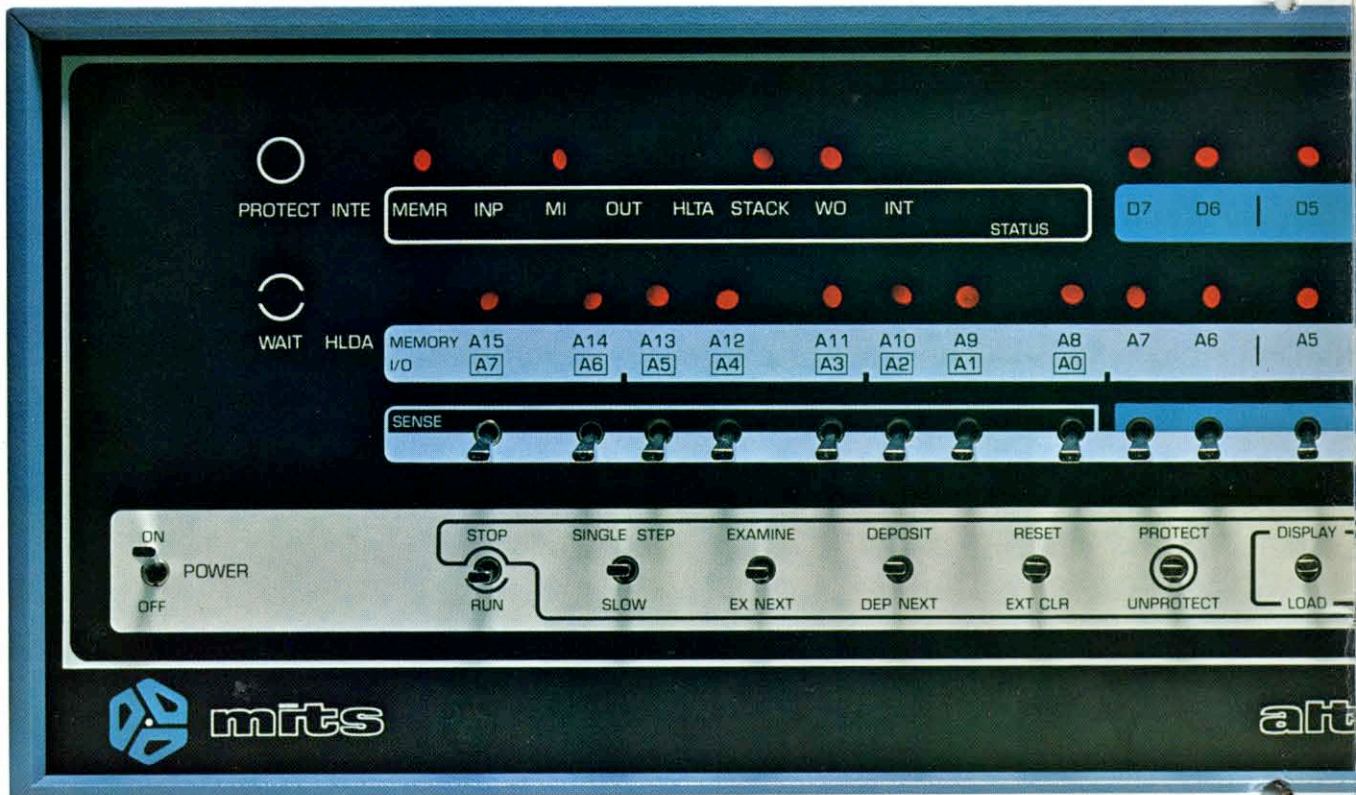

The Display/Control Board features a programmable read only memory (PROM) which contains the program operations for examine, examine next, deposit, deposit next and accumulator functions. The PROM eliminates the need for single-shot control of those functions.

The D/C Interface Board buffers all signals and aids in the isolation between the display/control board and the bus.

Data operations are controlled by the Intel 8080A CPU chip. An on-board crystal controlled clock generates the 2 MHz operating frequency and utilizes the Intel 8224 clock generator.

Display/Control Board to Display/Control Interface wiring is accomplished by the use of plug-in ribbon cables making these connections more sturdy and less subject to breakage.

All 8800 software and plug-in units are fully compatible with the 8800b (with the exception of the 8800a CPU board).

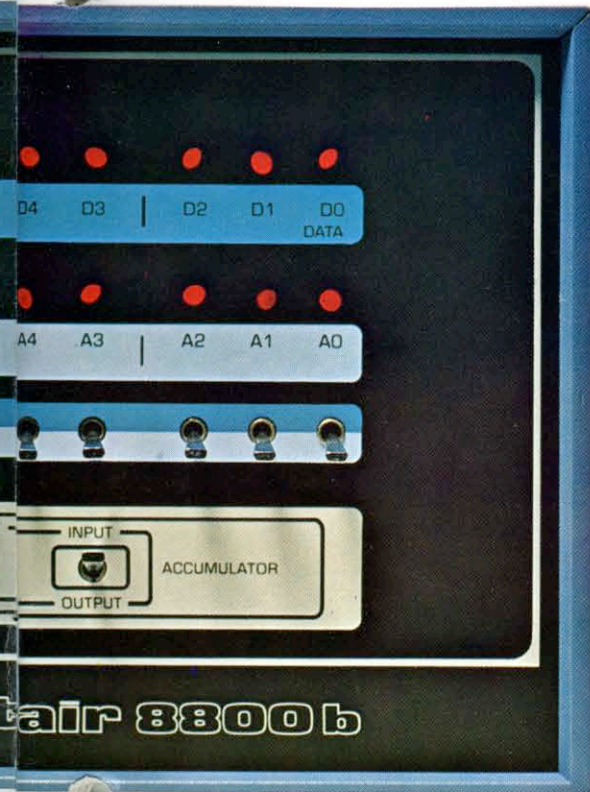
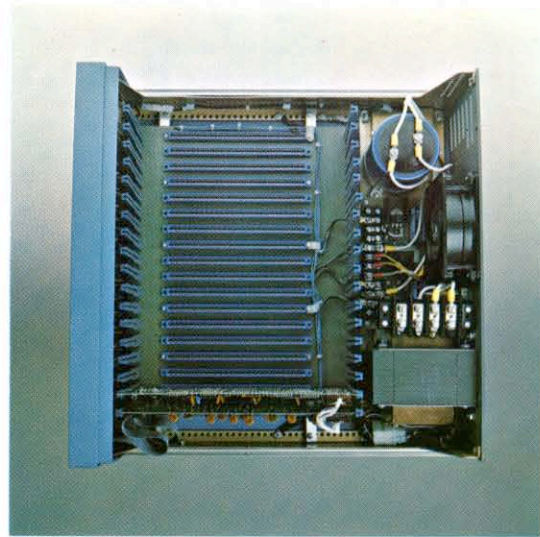

Specifications

Number of Boards	Up to 18	12 - \$995 - - \$1070 -
Microprocessor		
Model	8080A	
Technology	NMOS	
Data Word Size, Bits	8	
Clock Frequency	2M Hz	
Add Time, Register to Register,		
Microsec. per data word	2	
Number of Instructions	78	
Input/Output Control		
I/O Word Size, Bits	8	
Number of I/O Channels	256	
Direct Memory Access	Optional	
Interrupt Capability	Std.	
Vectored Interrupt (8 priority levels)	Optional	
Software		
Resident Assembler	Yes	
Higher-level Language	BASIC	
Monitor or Executive	System Monitor; text editor	
Complete Software Library		
Separately Priced	Yes	

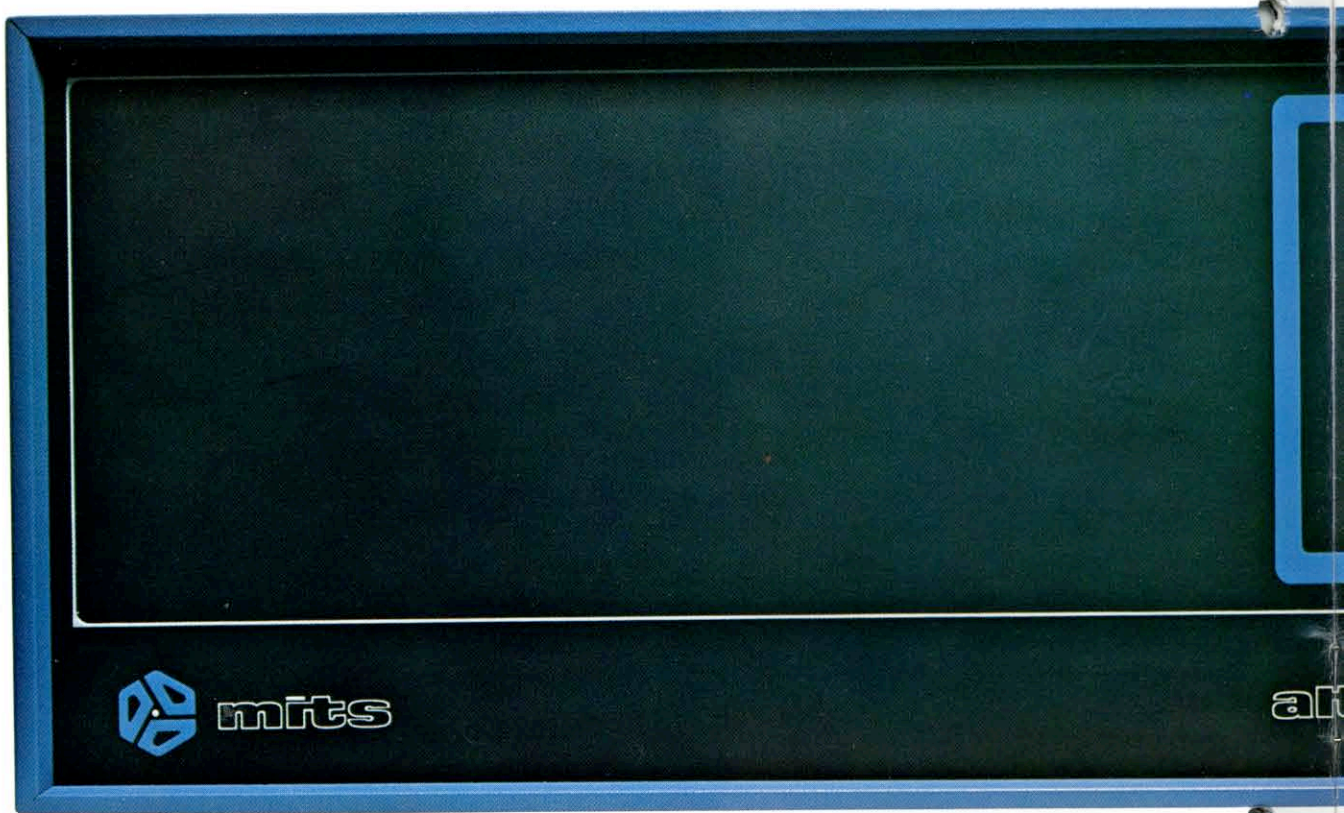

at

Altair 8800b Turnkey Model

Geared towards software enthusiasts and business applications, the 8800b Turnkey model is for the individual who does not require front panel operation.

Included on the Turnkey Module Board is a serial input/output (SIO) interface, 1K of RAM and provision for 1K of PROM* and sense switches. Extra I/O, PROM and RAM boards may be added. SIO interfacing can be made compatible with RS-232, current loop (TTY) or TTL. RAM and PROM locations are switch selectable to any two 1K blocks of the 64K bytes of memory accessible to the CPU.

The Front Panel Board contains the power switch which is key-locked for system security. A heavy duty power supply and an 18 slot motherboard allow up to 16 additional boards in the system (18 including the Turnkey Module board and CPU board).

**The Altair 8800b programmed PROM monitor, the Multi Boot Loader PROM and/or the Disk Loader PROM may be purchased separately and used on the Turnkey Module Board.*

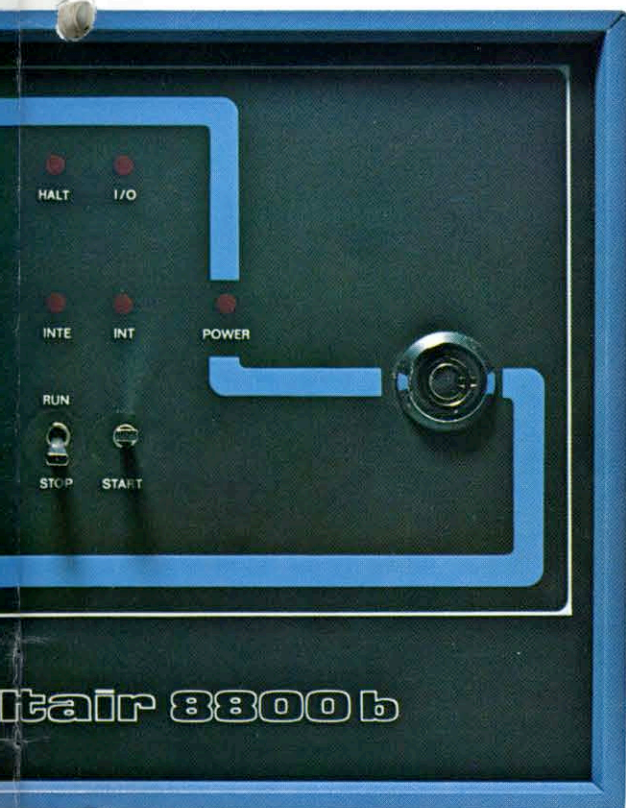

Specifications

Number of Boards	Up to 18
Microprocessor	
Model	8080A
Technology	NMOS
Data Word Size, Bits	8
Clock Frequency	2M Hz
Add Time, Register to Register,	
Microsec. per data word	2
Number of Instructions	78
Input/Output Control	
I/O Word Size, Bits	8
Number of I/O Channels	256
Direct Memory Access	Optional
Interrupt Capability	Std.
Vectored Interrupt (8 priority levels)	Optional

12-995
-01070

680b Mainframe

Complete computing capabilities at a low cost make the Altair 680b ideal for home computing and process control applications.

System design is based on the 6800 microprocessing unit (MPU). The MPU, along with 1K bytes of RAM memory, a 256 byte PROM monitor, a 6850 Asynchronous Communication Interface Adapter (ACIA) and provisions for an extra 1K of PROM are all contained on the 680b mainboard. Because these components are located on one board, this highly functional expandable system takes up very little space.

Immediate loading and running of programs in both BASIC and Assembly languages without entering bootstraps is made possible by the PROM Monitor.

The ACIA allows for software controlled interfacing to serial terminal devices. Input/Output operation may be configured for either RS-232 or TTY levels. An optional five level Baudot interface is also available.

System expansion is made possible by the addition of the 680b Expander Card, which plugs into the mainboard. Up to three extra boards may be inserted, such as supplemental memory or I/O interface channels.

Altair 680 BASIC, available on paper tape or audio cassette, contains most of the features of 8800 8K BASIC. Only 6.8K of memory space is required for loading and a copy is included free with the purchase of the Altair 680b 16K Memory Board.

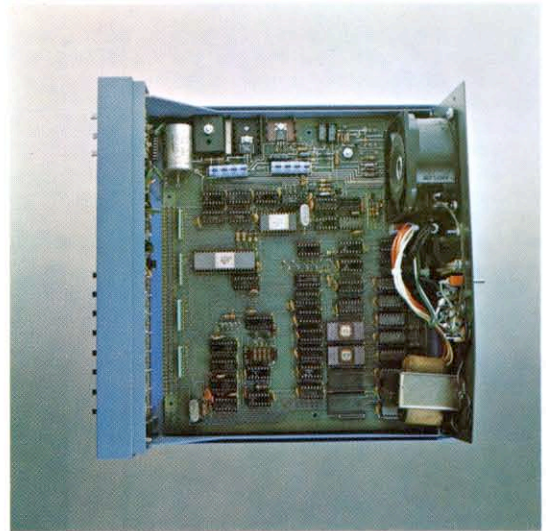

Altair 680b plug-in options shown on pages 27-28

* 495-

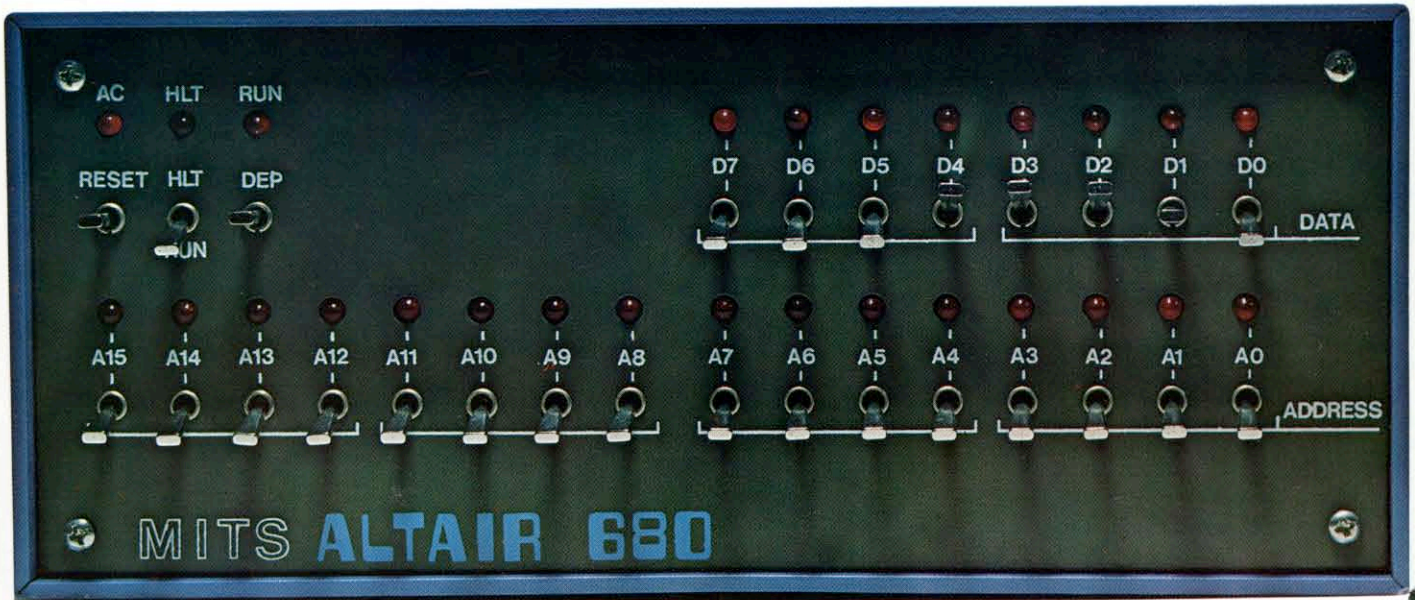

Specifications

No. of Boards	Up to 3 additional with second power transformer
Microprocessor	
Model	6800
Technology	NMOS
Data Word Size, Bits	8
Clock Frequency	500KHz.
Add Time, Register to Register Microsec. Per Data Word	2
Number of Instructions	72
Input/Output Control	
I/O Word Size, Bits	8
Number of I/O Channels	256 Memory Address Locations Designated
Interrupt Capability	STD.
Type of Interrupt System	Maskable (Interrupt Request) and Non-maskable interrupt
Software	
Resident Assembler and Editor	Yes
Higher-level language	BASIC
Monitor	Resident System Monitor on PROM.
Complete Software Library Separately Priced	Yes

Altair 680b Turnkey Model

For applications not requiring a full front panel, the Altair 680b computer is also available in a Turnkey Model. When used in conjunction with a terminal, the system PROM monitor eliminates the necessity for front panel control.

450 -

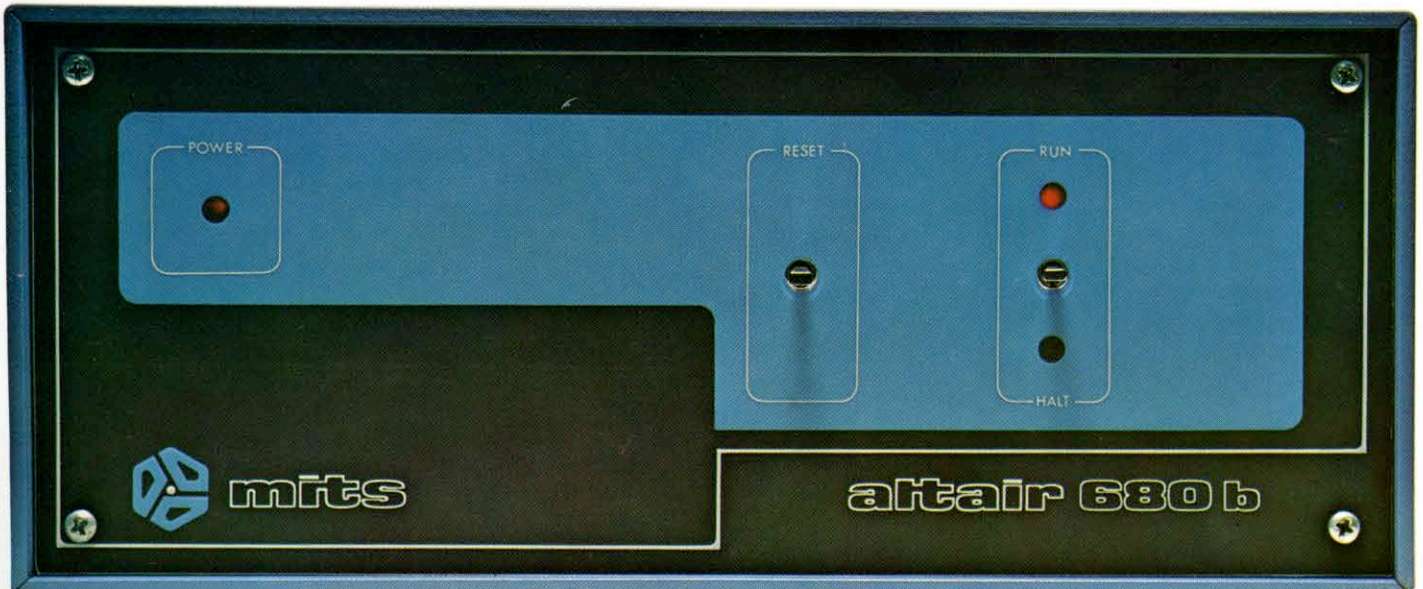

1150

Altair Minidisk System (88-MDS, 680b-MDS)

Similar to the 88-DCDD in operation, yet smaller in storage capacity and size, the MDS offers disk capabilities at a low cost. The Minidisk uses a smaller diskette (5 inches in diameter) that has a maximum storage capacity of over 71K bytes. Comprised of a disk drive and disk controller, the Minidisk system has a data transfer rate of 125,000 bits per second with an access time of under three seconds. To insure maximum life of the drive motor, a timer in the controller turns the system off if the Minidisk is not accessed for five seconds.

Altair Minidisk BASIC includes the standard features of BASIC plus extra functions for increased programming facilities.

Specifications

- Access Time:
 - Track to Track: 50 msec
 - Disk Enable to READ or WRITE: 1 sec (minimum)
 - Average Access Time: 1.85 sec (2.9 sec maximum)
- Rotational Speed: 300 RPM (200 msec/rev)
- Tracks: 35
- Sectoring: hard sectored, 16 sectors per track, 12.5 msec per sector
- Data Transfer Rate: 125,000 bits per sec
- Maximum number of drives per system: 4
- Data storage capacity: 71,680 bytes per minidiskette
- Data bytes per sector: 128
- Data bytes per track: 2,048
- Disk Drive MTBF: 8000 hours (25% motor run time)
- Service Life: 5 years
- Disk Drive reliability: not more than 1 in 10⁸ soft (recoverable) errors, 1 in 10¹¹ hard (non-recoverable) errors
- Power: Standby—25 watts typical, Operating—35 watts typical, 110/220 VAC, 50/60 Hz

1715

Altair Floppy Disk (88-DCDD)

Specifically designed for the Altair 8800b, the 88-DCDD hard-sectored floppy disk system permits mass storage and retrieval of over 300,000 bytes of data per diskette, at a data transfer rate of 250,000 bits per second.

The Altair Floppy Disk system is comprised of a Disk Controller and Disk Drive. Consisting of two PC boards, the Disk Controller can interface the Altair 8800b with up to 16 disk drives

The Disk Drive unit features a Pertec FD 400 Flexible Disk Drive, which offers direct drive dc motor operation that is insensitive to line

frequency variations. A fan is included to maintain low ambient temperature during continuous operation.

Software available for the 88-DCDD includes Altair Disk Extended BASIC, offering greater capabilities for saving/loading programs and manipulating data files on disk. Utility software comes with the Disk Extended BASIC package, enabling the user to copy diskettes, initialize blank diskettes and list directories. The disk bootstrap loader is available on paper tape, cassette tape or PROM.





Specifications

Access Time:

Track to Track: 10 ms.

Head Load and settle time: 45 ms.

Average time to read or write: 400 ms.

Worst case: 1135 ms.

Rotational speed: 360 RPM (166.7 ms/rev)

Tracks: 77 per disk

Sectoring: Hard sectored, 32 sectors per track, 5.2 ms/sector (non IBM compatible)

Data Transfer Rate: 250,000 bits/sec. (one 8-bit byte every 32 microseconds)

Maximum number of drives per system: 16

Data storage capacity: 310,000 bytes per disk

Data bytes per sector: 128

Data bytes per track: 4,096

Disk Drive head life: over 10,000 hours of diskette to head contact.

Disk Drive MTBF: exceeds 4,000 hours

Disk Drive data reliability: not more than 1 in 10^9 soft (recoverable errors), 1 in 10^{12} hard (non-recoverable errors)

Power:

Controller: 1.1 amps at +8V unregulated (from Altair bus)

Disk Drive Unit: 110 watts 50/60 Hz 117/220 VAC

Altair B-100 CRT Terminal

Begin communicating with your Altair computer right away through the Altair B-100 CRT terminal. The B-100 has switch selectable transmission from 75 to 19,200 bps and features cursor control, RS-232/current loop interfacing, addressable cursor and erase mode. A 12-inch, non-glare monitor is formatted to display 24 lines of 80 characters per line with a memory page of 1920 characters.



Display Format: 24 lines x 80 characters
Display: 12"
Character Type: 5 x 7 dot matrix
Character Set: 64 ASCII
Cursor Control: Left, Right, Up, Down, Home, Carriage Return, Line Feed
Communications Interface: Serial RS-232C, 20mA current loop
Transmission Rate: Switch Selectable, 75 to 19,200 bps
Addressable Cursor: Directly positions the cursor by line and column
Scroll: When display memory is filled and additional characters added, the display will scroll
Keyboard: 82 key, auto repeat, 2-key rollover, alpha lock and 11-key numeric pad
Input Voltage: 115/230 VAC $\pm 10\%$ at 50/60 HZ



LSI ADM-3 CRT TERMINAL

The ADM-3 video terminal may be used in any system designed for simple data transmission and quick retrieval. Its operation is fast and quiet, without the mechanical maintenance problems of other terminals.

This 12-inch, non-glare CRT terminal features a 24-line, 80 character per line display switch selectable baud rates (75-19,200) and RS-232/ current loop interfacing. An RS-232 extension connector lets you plug in asynchronous serial ASCII printers, giving you a permanent record of all information. Word format is user-selectable for your particular system and application.

Specifications

Display: 12" (diagonally measured) rectangular CRT screen with P4 phosphor and bonded etched non-glare surface.

Display Format: 1920 characters, 24 lines of 80 characters per line.

Character Set: 64 ASCII characters.

Character Generation: 5 x 7 dot matrix.

Cursor: Underline, homes to lower left of screen.

Computer Interfaces: EIA standard RS-232C and 20 mA. Current Loop (Switch Selectable).



Auxiliary Interfaces: Extension RS-232C port
Communication Rates: 75, 110, 150, 300, 600, 1200, 1800, 2400, 4800, 9600, 19,200 baud (switch selectable).
Transmit/Receive Modes: Full and half duplex (switch selectable).
Power Consumption: 70 watts at 115V \pm 10%.



A 2995

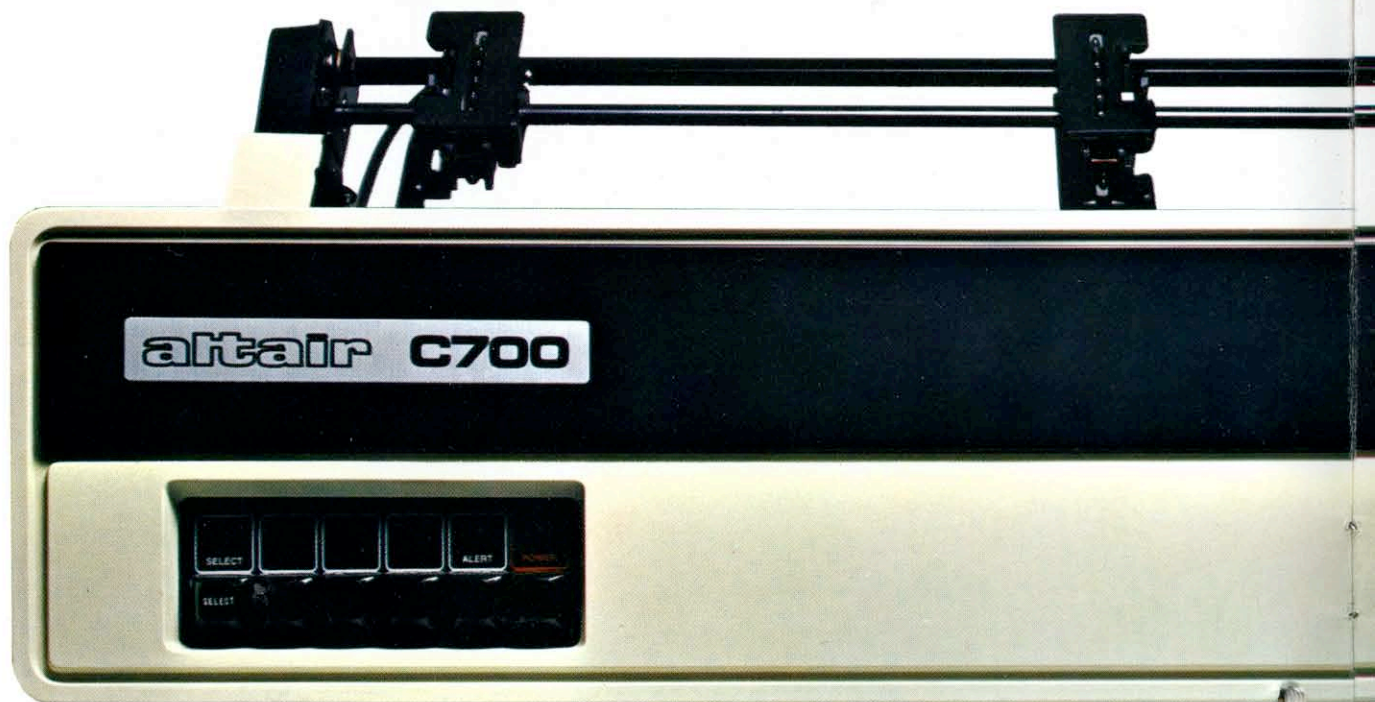
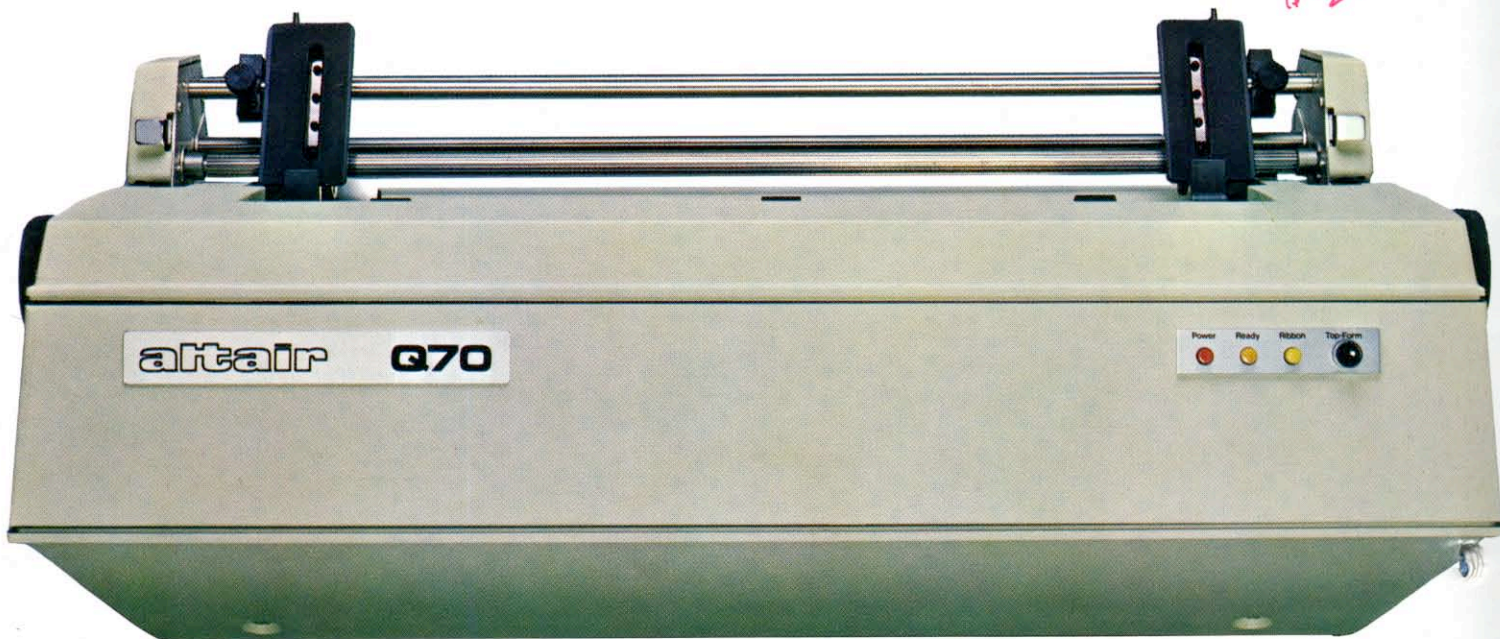

Altair Q-70 Printer

The Altair Q-70 is a 45 character per second "daisy wheel" printer that sets new standards in print quality and reliability. Excellent for business and professional applications requiring highest quality printing.

Features that would be special on most printers are standard on the Altair Q-70. They include: an MOS/LSI microprocessor that provides proportional ribbon advance, carriage roller bearings for reduced friction with better vertical print registration, a positive printwheel latch for optimum daisy wheel positioning resulting in superior print quality, fast ribbon lift offering greater speed and a full-tilt printwheel carriage for easier and cleaner printwheel changes.

Specifications

Printing Method: Impact, serial.

Printing Rate: 45 characters per second.

Data Input: 12 bit TTL levels plus controls.

Font: 96 character positions on a daisy printwheel.

Format: Horizontal—132 columns at 10 characters per inch. 158 columns at 12 characters per inch.

Vertical—Spacing increments of $\frac{1}{8}$ inch up or down; slew rate at 5 inches (12.7 cm) per second.

Plotting: Resolution of 5760 points per square inch.

Electrical Requirements: 115/230 VAC at 50/60 Hz.

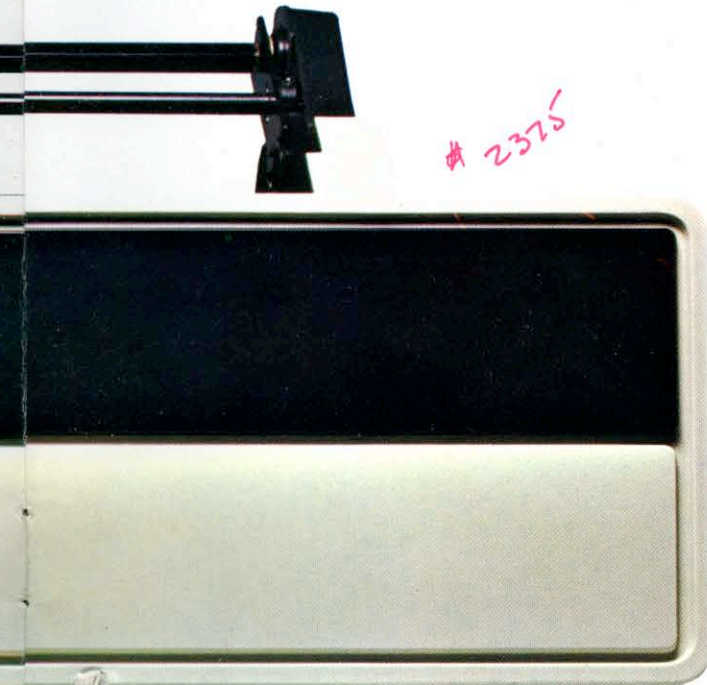

Altair C-700 Line Printer

Computer printouts suitable for a variety of small business uses can be produced by the Altair C-700 bidirectional line printer.

Bidirectional operation permits the printhead to move right and left, seeking the nearest margin of the next line. By printing in this manner, efficiency is increased by discarding the time-consuming carriage return.

Maintenance is supplied by the use of Large Scale Integration (LSI) to minimize component parts and improve functional reliability.

Specifications

Printing Method: Impact, character by character, bidirectional.

Printing Rate: 60 characters per second, 26 lines per minute.

Transmission Rate: Up to 75,000 characters per second.

Data Input: 7 | 8 bit ASCII parallel, TTL levels.

Character Structure: 5 x 7 dot matrix.

Format: 10 characters per inch horizontal, 6 lines per inch vertical.

Electrical Requirements: 115/230 VAC \pm 10%, 50/60 Hz.

Altair 7000 Graphics Printer

Acting as a printer, plotter or graphics device, the Altair 7000 GP is one of the fastest and most economical methods of electrostatic printing.

When used as a line printer, characters are generated utilizing a 5 x 7 dot matrix. Line widths of 20, 40 or 80 characters are selectable through software command. Printing speed is at 160 characters per second or 120 lines per minute.

An eighth printing electrode that provides equal horizontal and vertical spacing makes the 88-7000 ideal for graphics. Pictures can be produced that show either a distinct outline or a sophisticated, detailed picture with shaded areas.

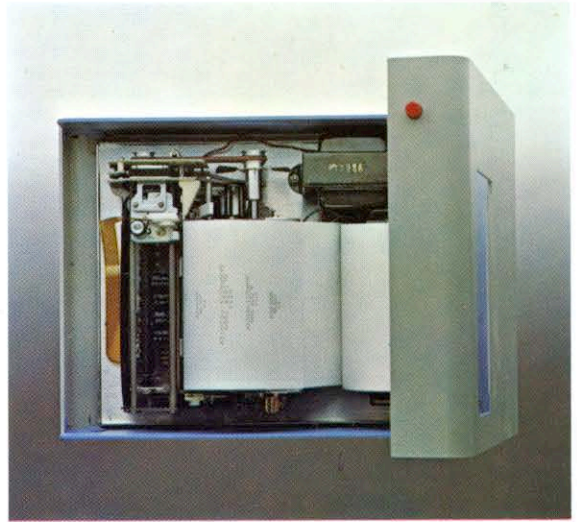

Specifications

Printing Medium: Electrosensitive paper (5 inches wide).

Horizontal Resolution: A. Internal timing—80 dots/inch.

B. External timing—better than 128 dots/inch.

Vertical Resolution: 65 dots/inch.

Printhead Speed: .0175 inches/msec $\pm 0.1\%$.

Timing Markers: A. Every $\frac{1}{80}$ inch of printhead travel (Dot Time). B. Every $\frac{1}{40}$ inch of printhead travel (Character Time).

Plotting Speed: Two lines per second, eight dots vertical.

Input Raster: Eight-bit parallel.

Power: 115v AC, 36W.

Interface: 1 PIO port.

785



ALTAIR SOFTWARE

MITS offers a wide range of sophisticated software to support the Altair 8800b and 680b systems. Altair software is painstakingly developed to provide an effective vehicle for rapid, straightforward program development.

The following packages are currently available:

#60/150 #75/200

Altair BASIC: 4K, 8K, Extended and Disk versions for use with the 8800 series microcomputers

#200/0

Altair BASIC for the Altair 680b microcomputer

200/45 450/200

Altair Timesharing BASIC

500/200

Altair Disk Operating System

#200/75

Package II

#75/0

Altair 680 Assembly Language Development System

#75-

PROM Bootstrap Loaders

Altair BASIC

Altair BASIC is one of the finest dialects of BASIC available. Designed to run programs in 4K, 8K and 16K of memory with a special version to support disk files, Altair BASIC has received industry-wide acclaim for numerous features not usually found in a microcomputer language.

Altair 8K BASIC

8K versions of Altair BASIC are available for both the Altair 8800b and the Altair 680b. Altair 8K BASIC is a high-level language that offers a number of powerful features including:

- Boolean operators for bit manipulation
- Variable length strings of up to 255 characters with LEFT\$, RIGHT\$ and MID\$ functions
- Concatenation operator for conversion between strings and numbers
- Ability to read or write a byte from any I/O port or memory location
- Program interrupt features that allow examination of variable values
- String and numeric arrays of as many as 30 dimensions
- Loop nesting limited only by available memory
- Intrinsic functions of SIN, COS, TAN, LOG, EXP, SQU, SGN, ABS, INT, FRE, RND, POS

Altair Extended BASIC

This high-level language possesses all the features of Altair 8K BASIC plus additional luxury items that provide increased capabilities. Minimum memory requirement: 16K.

Altair Disk BASIC

This superset of Altair Extended BASIC was developed specifically for the support of disk files. It provides the user with:

- Random or sequential file access
- Simultaneous use of multiple data files
- Utilities to format new disks

Minimum memory requirement: 24K

Altair Timesharing BASIC

The newest member of the Altair BASIC language family offers users a practical alternative to larger, more expensive systems. A version of Altair Extended BASIC, Altair Timesharing BASIC is available in two versions: Altair Timesharing BASIC and Altair Timesharing Disk BASIC. Both versions allow multiple users, running different programs, simultaneous yet independent access to a single Altair 8800b microcomputer.

Each program is confined to a separate area of memory, a security provision which prevents alteration or destruction by other users.

Input and output are interrupt driven and fully buffered to provide virtually instantaneous keyboard response.

With Altair Timesharing Disk BASIC, users may load and store programs on floppy disks.

Both versions offer other fine features:

- Extensive diagnostics for program debugging
- Automatic line numbering
- Line oriented text editor, with line and character manipulation capabilities

Minimum memory requirement: 32K

Altair DOS (Disk Operating System)

The Altair DOS package can be utilized to assemble and edit 8080 assembly language programs stored on floppy disk. It includes a Text Editor, Assembler with linking loader and a symbolic Debugger as well as System Monitor. Minimum memory requirement: 16K

Package II

Package II is an assembly language development system for the 8800 series microcomputers utilizing audio cassette and paper tape. It includes extensive diagnostics in addition to the following powerful features for program maintenance and development:

- Monitor: With I/O drivers for a system console, paper tape reader and audio cassette
- Text Editor: Line oriented with capabilities for string searches, line modification and deletion
- Assembler: Translates standard 8080 assembler code to machine code in a one-pass operation
- Debug: Provides flexible, interactive program modification with capabilities to allow user control to be passed from the program to Debug via breakpoints

Minimum memory requirement: 8K

Altair 680 Assembly Language Development System

The 680 Assembly Language Development System consists of Text Editor and Assembler operating at maximum efficiency when utilized in a co-resident manner.

The two-pass Assembler:

- Translates M6800 MPU source programs written in Motorola assembly code to the machine executable object code
- Provides a cross-referenced symbol table upon completion of pass two

The Text Editor is interactive with capabilities to:

- Create or modify source programs
- Manipulate lines, characters or strings

Minimum memory requirement: 8K

Altair Multi Boot Loader PROM, Altair Disk Boot Loader PROM

Handy multi boot loader PROM reduces the 30-plus steps for toggling the BASIC bootstrap from the front panel to five simple steps. The disk loader PROM loads BASIC from a floppy disk.

The Altair Software Distribution Company has announced the introduction of a comprehensive set of software packages designed for the small business system market. The ALTAIR BUSINESS SYSTEM includes complete software packages for ACCOUNTING, WORD PROCESSING, and INVENTORY MANAGEMENT. The software will operate as individual packages or as an integrated system to accommodate the needs of retail stores, small wholesale distribution centers, industrial users, professional firms, and other business offices.

The new Altair Business System is designed around the Altair 8800 Computer.

The system hardware may be individually configured for each installation and typically includes a CRT terminal, a typewriter-quality precision printer and two flexible disk units.

The component packages of the Altair Business System are available under a onetime fee licensing arrangement. The license fee includes up to three years of software maintenance. Each package is accompanied by a comprehensive set of documentation including operator and systems guides as well as training aids. For information on price and delivery or a personal demonstration, contact your local Altair computer dealer.



ALTAIR SOFTWARE DISTRIBUTION COMPANY

3330 Peachtree Road, Suite 343 Atlanta, Georgia 30326 404-231-2308

The Altair Business System software is packaged in modules to allow a purchaser to select the components of a system that will most closely fit his needs. All packages contain a complete set of prompts and other helping messages that allow even an inexperienced operator to make full use of the system with minimum instructions. Customization to conform the packages with exact end-user requirements is available.

The ACCOUNTING SYSTEM is comprised of four modules—general ledger, receivables, payables and payroll. The GENERAL LEDGER package is the heart of a financial reporting system for a small business. It allows a firm to keep a detailed monthly general ledger of all its transactions and generate a monthly balance sheet and income statement to provide timely information on the financial status of the company. The PAYROLL package allows a company to prepare its periodic payroll for hourly, salaried, and commissioned employees while accumulating the necessary information for tax reporting. It generates the monthly, quarterly, and annual returns to be filed with local, state and federal governments. It also prepares employee W-2s and maintains an up-to-date information reference for each employee. The payroll package includes tables for federal withholding and FICA as well as withholding for all 50 states and up to 20 cities from precomputed or user generated tables. The package will automatically produce payroll checks at the user's option. The RECEIVABLES package is a complete invoicing and monthly statement generating system that keeps track of the current and aged accounts receivable. The receivables package maintains a customer file with addresses and credit information as well as account status. The package allows the current status of any active customer account to be displayed. The PAYABLES package keeps track of current and aged accounts payable and incorporates a check writing feature. The payables package maintains a complete vendor file with information on purchase orders and discount terms as well as active account status. Each of the three subsidiary systems—receivables, payables and payroll—provides input directly to the general ledger package.

The WORD PROCESSING package is a flexible text editor system that allows large volume text material, such as contracts or other lengthy documents, to be stored, easily edited and printed. In addition, documents can call for inserts from other files or from the terminal, thereby making repetitive letters and complicated documents easy to produce. The text material is stored in a file without regard to pages or margins. In this way additional text material may be inserted conveniently while page headings, numbering, margins, spacing and other formats may be specified at the time of printing. A single document may contain up to 120,000 characters (about 45 single spaced pages) and documents may be linked for longer text. The text editor allows simple in-line corrections and extremely powerful global editing to be easily accomplished. The document files allow the user to "see" the embedded editing commands and line numbers thereby making corrections simpler. Documents are printed through a text formatter which arranges the text as specified by the user. The flexibility of the word processing package allows it to be used as a large document editor, a repetitive letter producer, a mailing list system, or a variety of other functions.

The INVENTORY MANAGEMENT package is a flexible data base management system which allows a business to keep complete inventory records "on line." In its off-the-shelf form, the Inventory Management package is structured for a typical retail store whose inventory reorder policy is based on minimum reorder points. Up to 1800 inventory items may be kept on line with a floppy disk based system. Some major reports include inventory Status, Exception, Analysis By Cost, and Order Status. The Point of Sale option prepares a sales receipt while automatically updating the inventory file and providing a direct sales entry for the general ledger.

A major advantage of the Altair Business System is that one machine can be used for many tasks in a small business: accounting, word processing, and inventory management. In addition, the same system will run Altair Disk BASIC, a powerful but simple computer language which allows many users to design and program their own software.

Memory

310

4K Static RAM Board (88-4MCS)

No need to refresh stored data with the fully static 88-4MCS. There are no wait states and little support circuitry is necessary resulting in a highly dependable memory device. Address selection is switch selectable in 4K increments. All logic and memory ICs are socketed.

Specifications

- Power: +8v unregulated at 1.2 A, Max.
- Access Time: 450 ns., worst case; 300 ns; typically.
- Memory Array: 4096 8 bit words.
- Memory Configuration: 1024 x 1.
- Dimensions: 10" x 5"

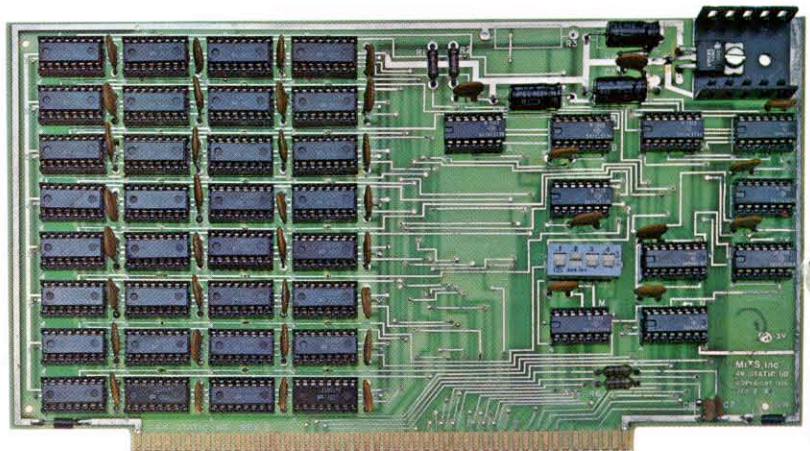

795

16K Static Memory Board (88-16MCS)

A welcome addition to any 8800 series system, the 88-16MCS is the perfect way to expand the memory in your Altair computer. The board provides a maximum capacity of 16,384 bytes of Random Access Memory while offering reliable operation, low power consumption and extremely fast access time. Due to the fast access time, the board has no wait states eliminating the need for additional refresh and support circuitry. Board addressing is switch selectable and all RAM IC's are socketed.

Specifications

- Power: +5v (400 mA, max.)
- +12v (160 mA, max.)
- 5v (100 mA, max.)
- Access Time: 215 ns.
- Cycle Time: 390 ns.
- Memory Array: 16,384 8 bit words.
- Memory Configuration: 4,096 x 1.
- Dimensions: 10" x 5"



Synchronous 4K Memory Board (88-S4K)

The 88-S4K is a 4K memory board that employs low power synchronous operation by relying on the CPU for timing signals. Thus, the need for on-board single shot circuitry is eliminated. Because the synchronous process requires fewer critical timing parameters than single shot configurations, the 88-S4K offers reliable memory storage, free of timing problems.

Specifications

Power: +5v (450 mA, max.)
+12v (290 mA, max.)
+12v (unselected, 10mA, max.)
Access Time: 200-300 ns.
Memory Array: 4,096 8 bit words.
Memory Configuration: 4,096 x 1.
Dimensions: 10" x 5"

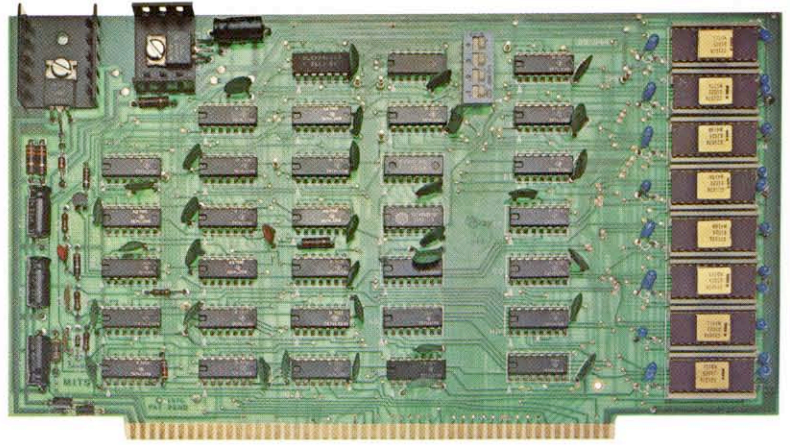

Synchronous 16K Memory Board (88-16MCD)

16K bytes of low power, fast Random Access Memory are combined with synchronous, no-wait-state operation in the 88-16MCD. On-board refresh circuitry receives timing signals from the CPU. The need for one-shot circuitry is eliminated by this improvement in timing signal generation. Power dissipation is a low 2.5 watts per board.

Specifications

Power: +5v at 282 mA.
-5v at 9.25 mA.
15v at 72 mA.
Access Time: 350 ns.
Cycle Time: 500 ns.
Memory Array: 16,384 8 bit words.
Memory Configuration: 4,096 x 1.

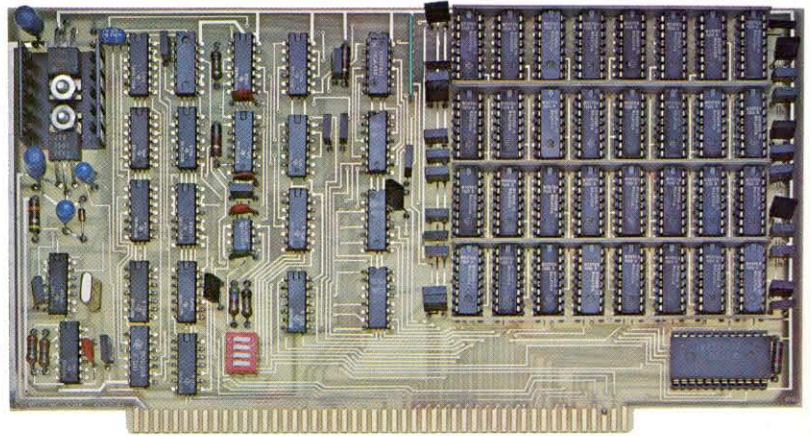

PROM Memory Card (88-PMC)

For the system requiring non-volatile read only memory, the 88-PMC can support up to 2K bytes of electrically programmable PROM and/or ROM. These memories provide permanent retention of start-up routines, bootstraps or dedicated control programs eliminating the need for front panel loading.

The PROM card offers the option of power down circuitry in order to reduce current drain when PROMs are not enabled.

Specifications

Power: +8v at 500mA.
-16v at 30-50 mA with PROM "on"
5-10 mA with PROM "off"
PROM Type: 1702 or 1702A.
Memory Size: 2,048 bytes (maximum).
Access Time: .75 microseconds—2 microseconds (depending on device).
Dimensions: 10" x 5"

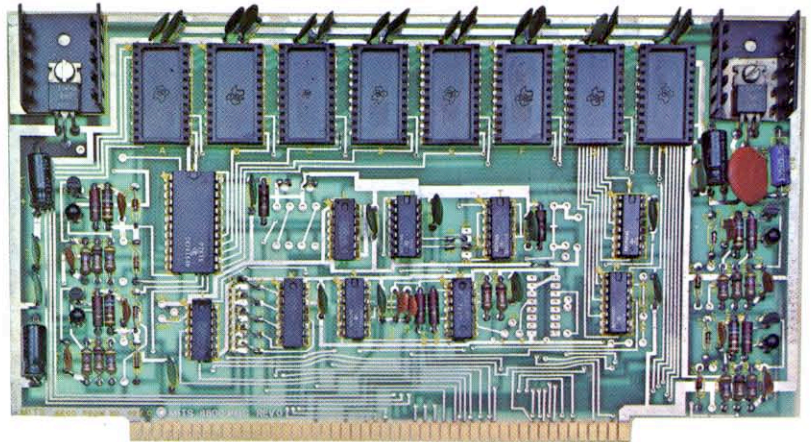

88-Two Port Serial Interface Board (88-2SIO)

195

Serial interface control and handshake operation may be programmed to meet individual requirements through the use of the 88-2SIO board. By utilizing both ports, two serial I/O devices can be simultaneously interfaced—each with its own, user-determined baud rates and electrical interconnects. Thus, two devices can operate independently such as an RS-232 CRT terminal at 9600 baud and a 20 mA TTY at 110 baud.

Specifications

Power: +5v at 520 mA.
 +15v at 70 mA.
 -15v at 70 mA.

Interface Levels: RS-232, 20 mA current loop, TTL.
 Baud Rates: 37.5, 75, 110, 150, 300, 450, 600, 1200, 2400, 4800, 9600.

Addressing: Selectable by jumper.
 Bit Configuration: Software selectable for 7 or 8 bits, 1 or 2 stop bits, odd or even parity.
 Ordering Information: Board comes with one port—additional port priced separately.

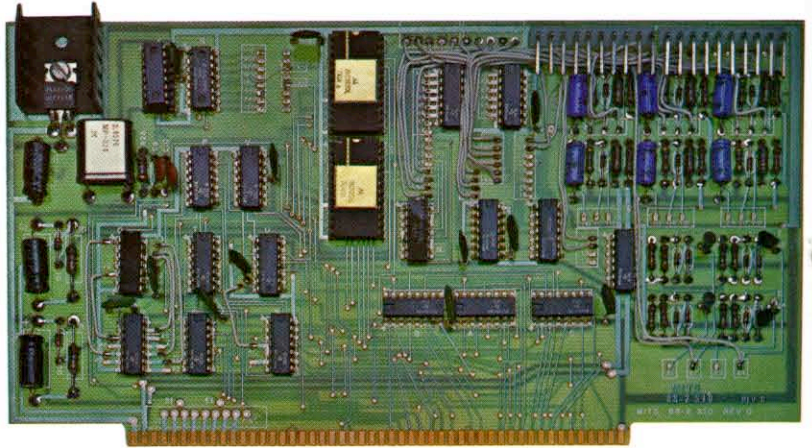

88-Four Port Parallel Interface (88-4PIO)

130

The 88-4PIO lets you communicate with up to four parallel I/O devices at the same time. Typical uses include interfacing with high speed printers, paper tape readers/punches, keyboards and tape drives.

88-4PIO options such as data direction (input or output) and interrupt/control structure are software selectable. All data lines are fully TTL compatible and may be configured for any combination of custom applications.

Specifications

Power: +5v at 500 mA with 4 ports.
 Number of ports: 1 to 4.
 Data Lines per Port: 16.
 I/O Level: TTL.

Drive Capability: 8 lines at each port can drive 1.5V at 1 mA.
 Control Lines: 4 per port under software control.
 Interrupt Lines: 2 per port under software control.

Addressing: Selectable by jumper, four addresses required for each port.
 Ordering Information: Board comes with one port—additional ports priced separately.

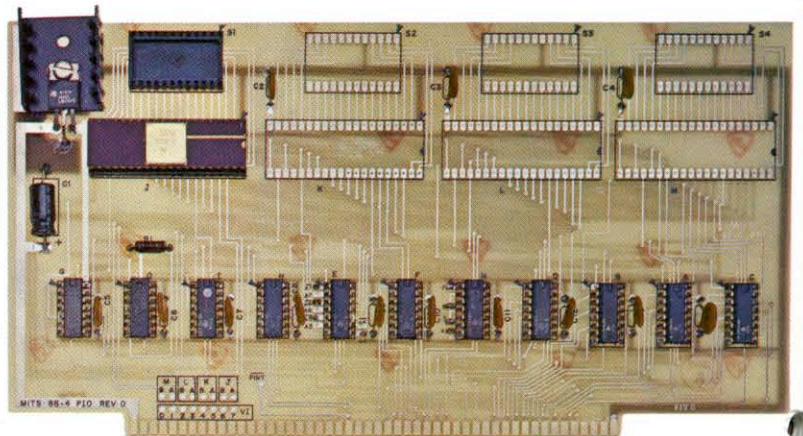

195

88-Audio Cassette Interface (88-ACR)

If you want to use your cassette recorder for inexpensive storage of programs, equip your Altair 8800b computer with an 88-ACR. Data is written on the tape by frequency modulation of the digital information. To read data, audio tones are filtered and then demodulated by a phase locked loop.

Altair BASIC commands, CSAVE and CLOAD, are used to save and load programs or data arrays. Any tape recorder with less than 2% wow/flutter and minimum speed fluctuations will provide dependable data storage and integrity.

Specifications

Modulation Frequencies: Logic 1—2400 Hz,
Logic 0—1850 Hz.

Data Rate: 300 baud, 30 bytes/sec.

Bit Format: UART type (1 start bit, 8 data bits,
1 stop bit).

Output Level: 100mV p-p sawtooth, suitable for
"MIC" input of recorders.

Output Impedance: 105K ohms.

Input Level: 200mV p-p to 10V p-p.

Input Impedance: 100K ohms.

Speed Tolerance: 2% without adjustment of PLL,
5% with adjustment of PLL.

Connector Type: 3.5 mm (1/8 in.) miniature
phone jack.

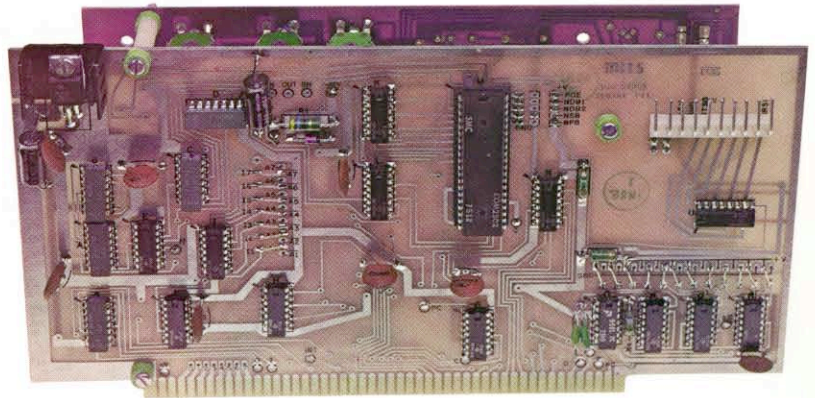

88-TTL Serial Interface (88-SIOB)

Interface your Altair Computer to a ham RTTY or CW station with the 88-SIOB. This board meets all FCC regulations for the design of ham stations; it can be strapped to provide 45 baud, 5 level baudot, 7.5 or 8 unit RTTY port, CW port and transmitter on/off control port.

Data lines are buffered to decrease the required input current to .5 mA (worst case) and increase the drive capability to 20 TTL loads (48 mA).

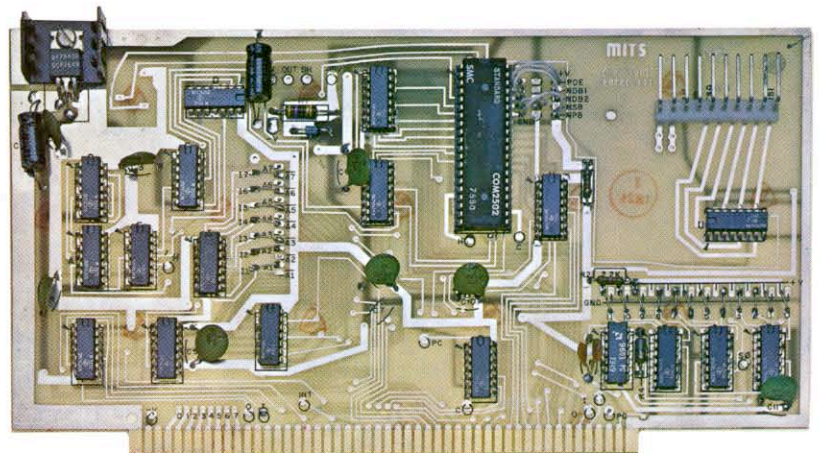

Special Purpose

235

88-PROCESS CONTROL INTERFACE (88-PCI)

Altair 8800b users wishing to control the operations of almost any electrical or mechanical device may do so with an Altair 88-PCI board. Through the use of relays, opto-couplers and software, the PCI receives process information and transmits control signals. A complete interrupt structure and handshake configuration are included, both software controllable.

Possible applications are practically unlimited: Monitor environmental conditions (heat, light, humidity) in the home or laboratory; control devices; control automatic sorting and grading of products on an assembly line; read and respond to scientific test results, such as changes in pressure, pH or viscosity.

Specifications

Opto-Isolators

Isolation: Resistance input to output: 200G ohms. Voltage: 15V min.

Input active current: 10-100ma.

Propogation delay: Varies with diode current from input to data (D) line.

Diode and Transistor: Turn on: 6 μ sec., typ. Turn off: 10 μ sec., typ.

Relay Outputs

Isolation: Contact to contact 750V AC at 250M ohms. Contact to coil frame: 2000V AC.

Propagation delay: Pull in: 3.5 msec.

Release: 4 msec., Bounce: 1.2 msec.

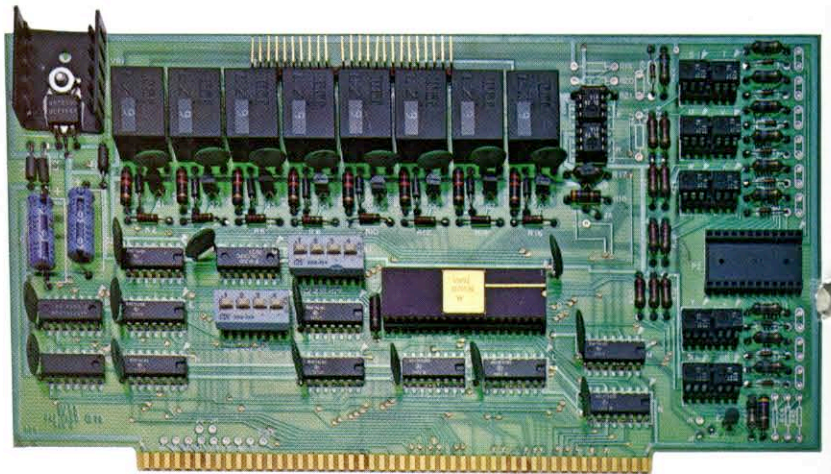

88-Analog to Digital/Digital to Analog Converter (88-AD/DA)

375

By utilizing an 88-AD/DA in your Altair 8800b, analog voltages are measured and generated to eight bit accuracy. This eight channel analog I/O system allows the acquisition and digitizing of analog data ranging from 0 to 10 volts DC.

The versatility of the 88-AD/DA permits user implementation for applications where these conversions are necessary. 88-AD/DA operation will be found useful for computer control, graphics production, games, scientific/electronic experimentation and monitoring.

Specifications

AD Section

Input MUX Channels: 8

Resolution: 8 bits

Monotonicity: 8 bits

Sample and Hold Settle Time: 5 usec.

Conversion Time: 5 usec.

DA Section

DA Converters: 2

Resolution: 8 bits

Monotonicity: 8 bits

Settle Time: 85 ns (50 v/usec.)

Nominal Output Range: 0-10 VDC (39 mV per step)

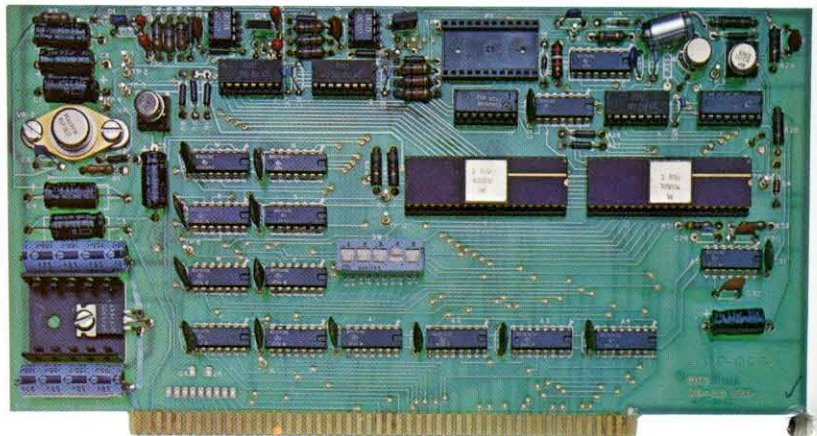

Power Requirements

+18V unregulated at 45 mA

-18V unregulated at 47 mA

+8V unregulated at 450 mA

88-Analog to Digital Converter (88-ADC) 524

Analog voltages often encountered in technical applications may now be measured and utilized by the Altair 8800b. The 88-ADC is a high accuracy converter that translates analog signals into 12 bit words, then inputs them to your Altair 8800 computer.

Employ the 88-ADC for a variety of scientific and industrial process monitoring uses: pressure, temperature, viscosity, optical density or frequency. In the home, the 88-ADC can function in remote control devices, video games and computer graphics.

Specifications

Power: +5V at 500 mA
+15V at 25 mA
-15V at 30 mA

Multiplex Channels: 8

Conversion Time: 65 μ s (max.) Module time only; processing time is not included.

Accuracy Rate: Quantizing error— $\pm 1/2$ LSB.

Nonlinearity— $\pm 1/2$ LSB.

Offset—Externally adjustable to zero.

Input Impedance: 1 M Ω (100 M Ω with Option #1).

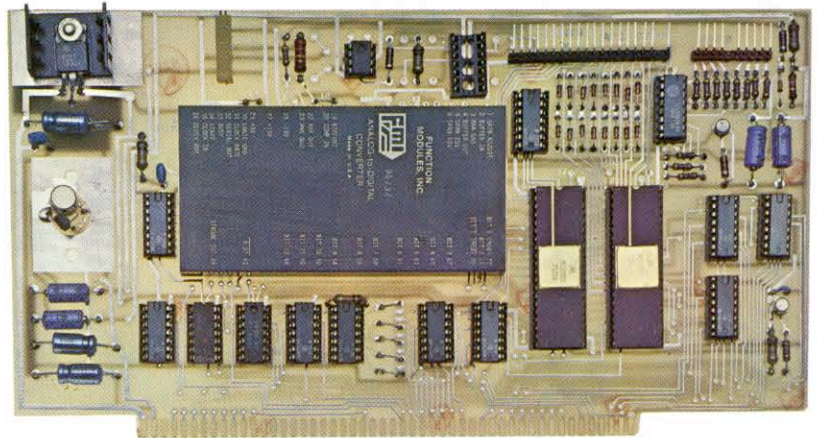

Stability Coefficients: Offset vs. Temperature—20 ppm/ $^{\circ}$ C (max). Gain vs. Temperature—80 ppm/ $^{\circ}$ C (max). Nonlinearity vs. Temperature—20 ppm/ $^{\circ}$ C (max). Gain vs. Supply Voltage— ± 30 ppm/% Vs (max).

88-Multiplexer (88-MUX) 319

By utilizing an 88-MUX in conjunction with the 88-ADC, you can expand the analog input capacity to 24 channels. A maximum of four 88-MUX cards may be added to a system, permitting up to 96 channels.

Voltage gain is user selectable from 1 to 1000 by choosing the proper feedback resistors. Each channel's filtering and scale factoring may be set independently. This feature allows a variety of I/O devices to operate simultaneously, providing great flexibility of system design.

Differential inputs for use in low noise/small signal applications are optional.

Specifications

Power: +5V at 40 mA
+15V at 180 mA
-15V at 180 mA

Settling time of the output to .01% of the final value occurs within 15 μ sec.

Input impedance is approximately 1 M., while offset is 5 mV (max).

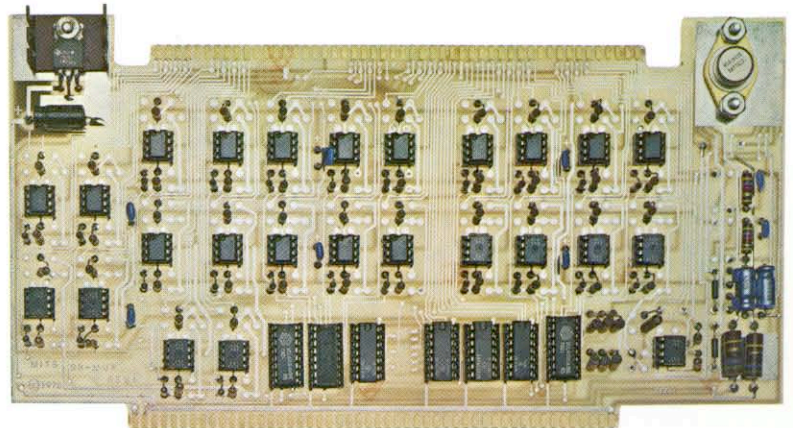

88-Vector Interrupt/Real Time Clock (88 VI/RTC) 185-

For sophisticated applications requiring several levels of interrupt, the Vector Interrupt Board permits you to interrupt running programs with eight levels of priority. The real time clock option allows interval selection of interrupts or preset repetition of an operation. Two time bases are available for use as the RTC clock—either 60 Hz from an AC line or 2 MHz system clock. Interrupt enable and disable is software controlled.

Specifications

Power: 5V at 300 mA
Clock Source Intervals: System Clock (2MHz)—100 ns, 1 ms, 10 ms or 100 ms.
Line Frequency (60 Hz)—16.67 ms, 166.7 ms, 1.667 sec or 16.67 sec.
Accuracy: 2MHz, .01%.

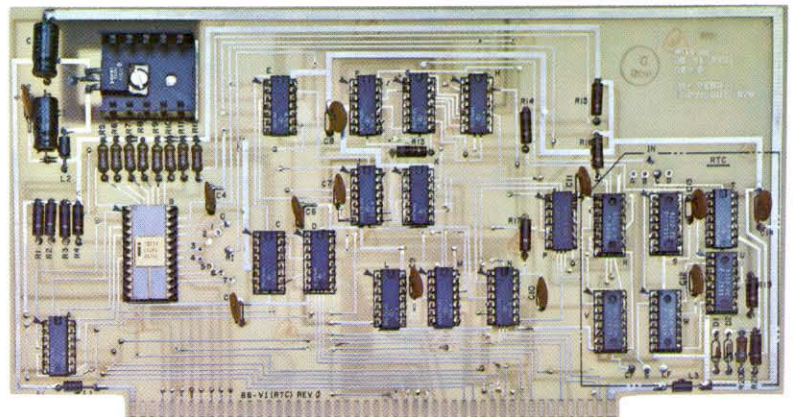

680b

865

16K Static Memory Card (680b-BSM)

Memory expansion of the 680b is now possible with the addition of the 680b-BSM. Up to three of these fast access, low power 16K Static Memory Cards may be included in the system giving the 680b a memory capacity of 49K, including the existing 1K on the mainboard.

Board addressing is switch selectable in 16K increments. Sockets are provided for all IC's and all areas not to be soldered are covered by an epoxy solder mask.

Specifications

Power: +16v (130mA, Max.);
 -16v (110mA, Max.);
 +9v (150mA, Max.)

Access Time: 215 ns., max.

Cycle Time: 400 ns., min.

Memory Array: 16,384 8 bit words

Memory Configuration: 4,096 x 1

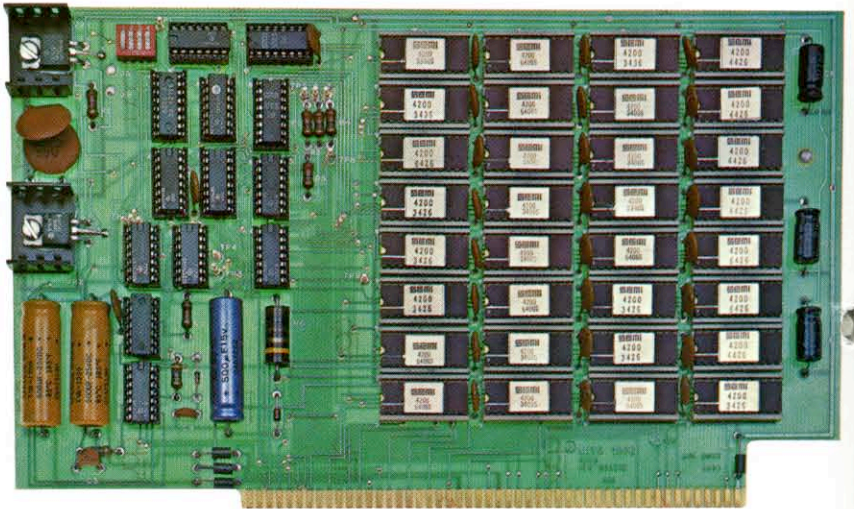

160

680b Universal I/O Board

Diversify the I/O capabilities of the Altair 680b—add up to two parallel ports and one serial port to your system with our Universal I/O Board.

Serial I/O lines are switch selectable for such RS-232, TTY and TTL devices as CRT's, teletypes or modems. The parallel ports are used to interface TTL

data through such peripherals as the line printer and high speed paper tape reader. Thirteen switch selectable baud rates (for serial interfacing) are available.

Specifications

Power: Fully expanded: +9v unregulated at approximately 350 mA.

TTY: Receive and Transmit lines only: +16v at 44mA typical, -16v at 20mA typical.

TTY: All input and output lines in use: +16v at 60mA typical, -16v at 60mA typical.

ACIA not used: +16v at 0 amps, -16v at 0 amps.
 RS-232 with maximum inputs and outputs: +16v at 0 amps. -16v at 4.8mA typical.

Baud Rates: 50, 75, 110, 134.5, 150, 200, 300, 600, 1200, 1800, 2400, 9400, 9600.

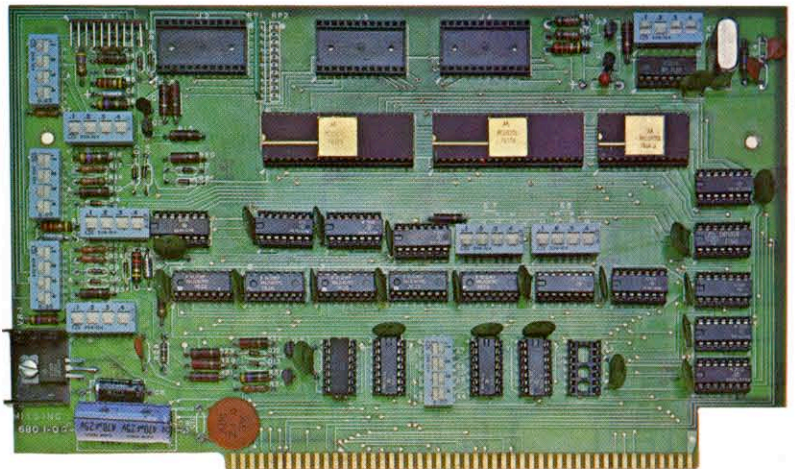

680b-KCACR

Audio cassette interfacing for the Altair 680b is provided by the 680b-KCACR. Based on the Kansas City Standard, data transfer is at a rate of 300 baud with a +20, -20 playback speed tolerance. This method also allows for variations in tape speed and head alignment. These flexible operating characteristics offer a high degree of reliability without circuitry adjustments in a variety of conditions.

Specifications

Demodulator Playback Speed Tolerance: +20, -20% from recorded speed.

Demodulator Input Levels (Playback): 300mv peak to peak minimum (100mv RMS).
10v peak to peak maximum (3.5v RMS).

Demodulator Input Impedance: 10K ohms.

Modulator Output Level: 30mv P-P (suitable for microphone input).

Modulator Output Impedance: 1K ohms.

Error Rate: Relative to quality of recorder and tape, typically less than 1 error in 10^6 bits READ with low noise audio tape.

Power Requirements: +8 volts unregulated—220mA typical. -16 volts unregulated—50mA typical (less than 3 watts total power).

250-

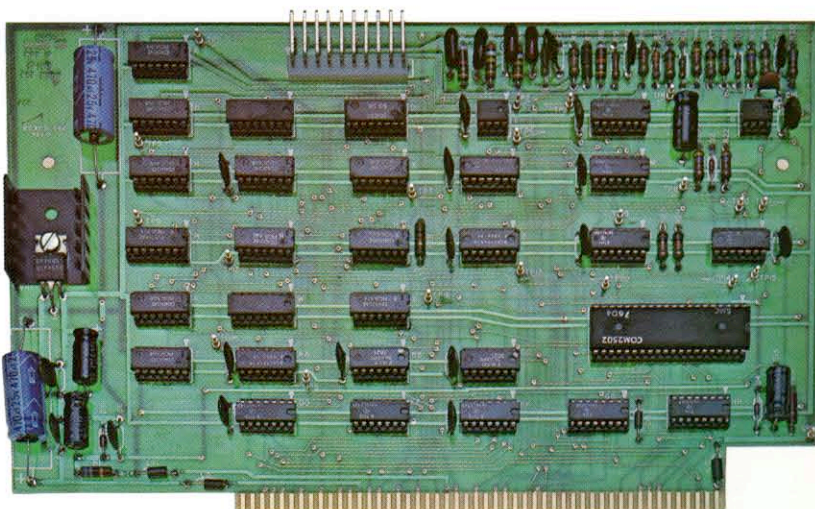

680b-Process Control Interface (680b-PCI)

Process monitoring and control for Altair 680b system owners is achieved with the 680b-PCI. In situations where certain conditions need to be maintained, the 680b-PCI can monitor and compensate for any deviations. Opto-isolator inputs, relay outputs and software are combined to receive and analyze process information—then transmit control signals. Possible applications in industry, home, science, business or communication are practically unlimited.

Specifications

Opto-Isolators

Isolation: Resistance input to output: 200G ohms. Voltage: 15V min.

Input active current: 10-100ma.

Propagation delay: Varies with diode current from input to data (D) line.

Relay Outputs

Isolation: Contact to contact 750V AC at 250M OHMS. Contact to coil frame: 2000V AC.

Propagation delay: Pull in: 3.5 msec.

Release: 4 msec. Bounce: 1.2 msec.

235

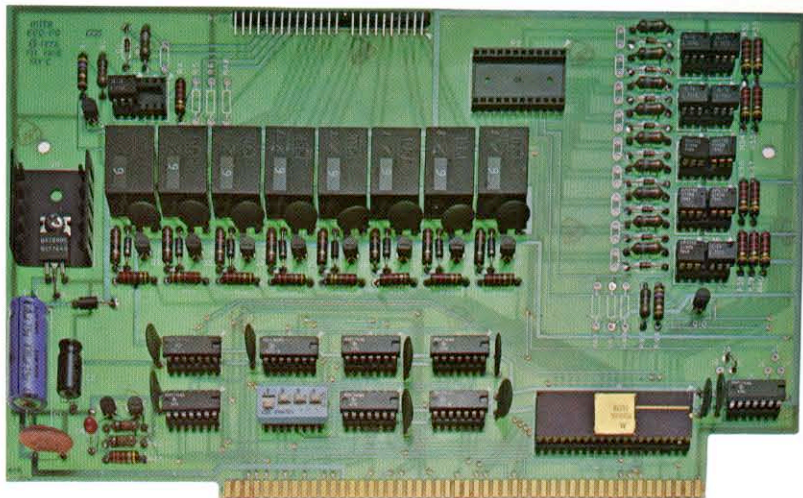

Altair Computer Centers

For expert assistance in planning and implementing your microcomputer system, visit the qualified people at one of these Altair Computer Center locations.

TUCSON, AZ 85711
4941 East 29th St.
(602)-748-7363

BERKELEY, CA 94710
1044 University Ave.
(415)-845-5300

SANTA MONICA, CA 90401
820 Broadway
(213)-451-0713

DENVER, CO 80211
2839 W. 44th Ave.
(303)-458-5444

ATLANTA, GA 30305
3330 Piedmont Road
(404)-231-1691

PARK RIDGE, IL 60068
517 Talcott Road
(312)-823-2388

ANN ARBOR, MI 48104
310 East Washington Street
(313)-995-7616

MADISON HEIGHTS, MI 48071
505-507 West 11 Mile St.
(313)-545-2225

EAGAN, MN 55122
3938 Beau D'Rue Drive
(612)-452-2567

ST. LOUIS, MO 63130
8123-25 Page Blvd.
(314)-427-6116

LINCOLN, NB 68503
611 N. 27th St. Suite 9
(402)-474-2800

CHARLOTTE, N.C. 28205
1808 E. Independence Blvd.
(704)-334-0242

ALBUQUERQUE, NM 87110
3120 San Mateo N.E.
(505)-883-8282, 883-8283

ALBANY, NY 12211
269 Osborne Road
(518)-459-6140

NEW YORK, NY 10018
55 West 39th Street
(212)-221-1404

DAYTON, OH 45414
5252 North Dixie Drive
(513)-274-1149

TULSA, OK 74135
110 The Annex
5345 East Forty First St.
(918)-664-4564

BEAVERTON, OR 97005
8105 SW Nimbus Ave.
(503)-644-2314

DALLAS, TX 75234
3208 Beltline Road, Suite 206
(214)-241-4088 Metro—263-7638

HOUSTON, TX 77036
5750 Bintliff Drive
(713)-780-8981

RICHMOND, VA 23230
4503 West Broad St.
(804)-335-5773

SPRINGFIELD, VA 22150
6605A Backlick Road
(703)-569-1110

CHARLESTON, W.VA. 25301
Municipal Parking Building
Suite 5
(304)-345-1360

